



FIRST-CUT
EARLY ENTRY PRODUCTS



DIAMOND PRODUCTS LIMITED
333 Prospect St., Elyria, OH 44035 U.S.A.

800-321-5336
diamondproducts.com

CC150XL-EE FIRST-CUT™ SAW

Powered By:



Website Product Page

LIGHT WEIGHT & PORTABLE



6.5" Blade Capacity
Electric
Gasoline

FEATURES

- Reliable skid plate system for green concrete
- Spring-loaded skid plate that stays down on the surface to help prevent spalling
- Heavy duty design but light weight enough for two people to lift
- Fully adjustable handle bars for operator comfort
- Five wheels under the frame for increased stability
- Cyclone air filter for increased air flow
- Up-cut design to keep debris from going back in the cut
- Blade raise/lower mechanical mechanism with spring loaded release
- Single ribbed drive belt
- Includes vacuum attachment guard plate



For use with a full line of Basic and Expert diamond blades

SPECIFICATIONS

Max. Depth of Cut	1.5" with 6.5" diameter blade
Blade Shaft RPM	4020
Blade Shaft Diameter	1-1/4"
Arbor Size	1"
Depth Indicator	Standard
Dimensions	16.94" wide, 21.80" tall, 32.92" long



CC150XL-EE FIRST-CUT™ SAW

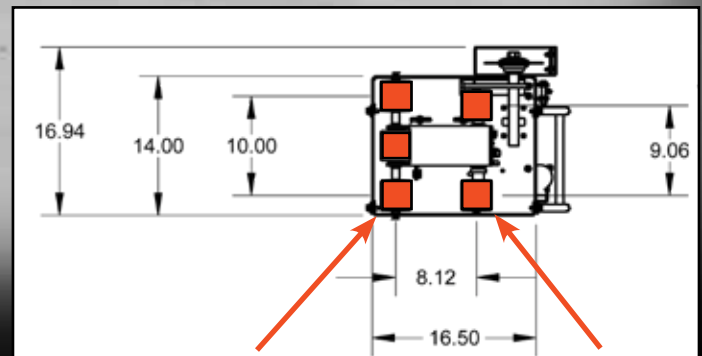
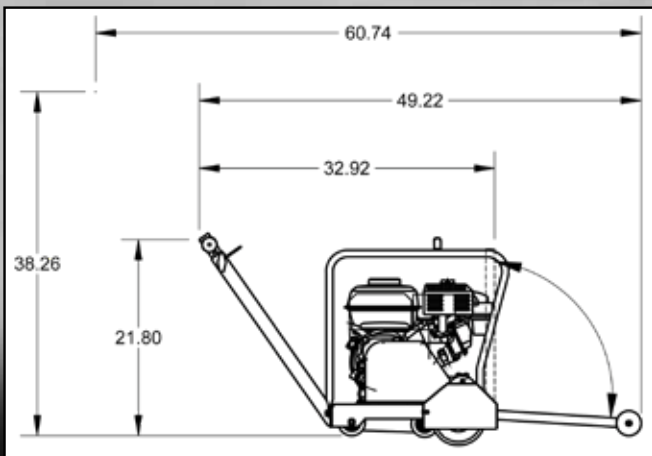

Five wide wheels for saw stability and reliable tracking

CC150XL-EE EARLY ENTRY SAW

Model #	Engine Make/Model	Engine Power*	Part #	Cat #	Product Weight (lbs)
CC125BXL-EE6	Baldor Electric	2.5 HP	5801357	07789	120
CC148HXL-EE6	Honda® GX160	4.8 HP, 7.6 Torque (lbs.-ft.)	5801345	32739	100
CC165BVXL-EE6	Briggs® Vanguard	6.5 HP	5801346	32747	105

*Horsepower as rated by the engine manufacturer.



CC190PRO-EE FIRST-CUT™ SAW

PROFESSIONAL GRADE PERFORMANCE



Website
Product Page

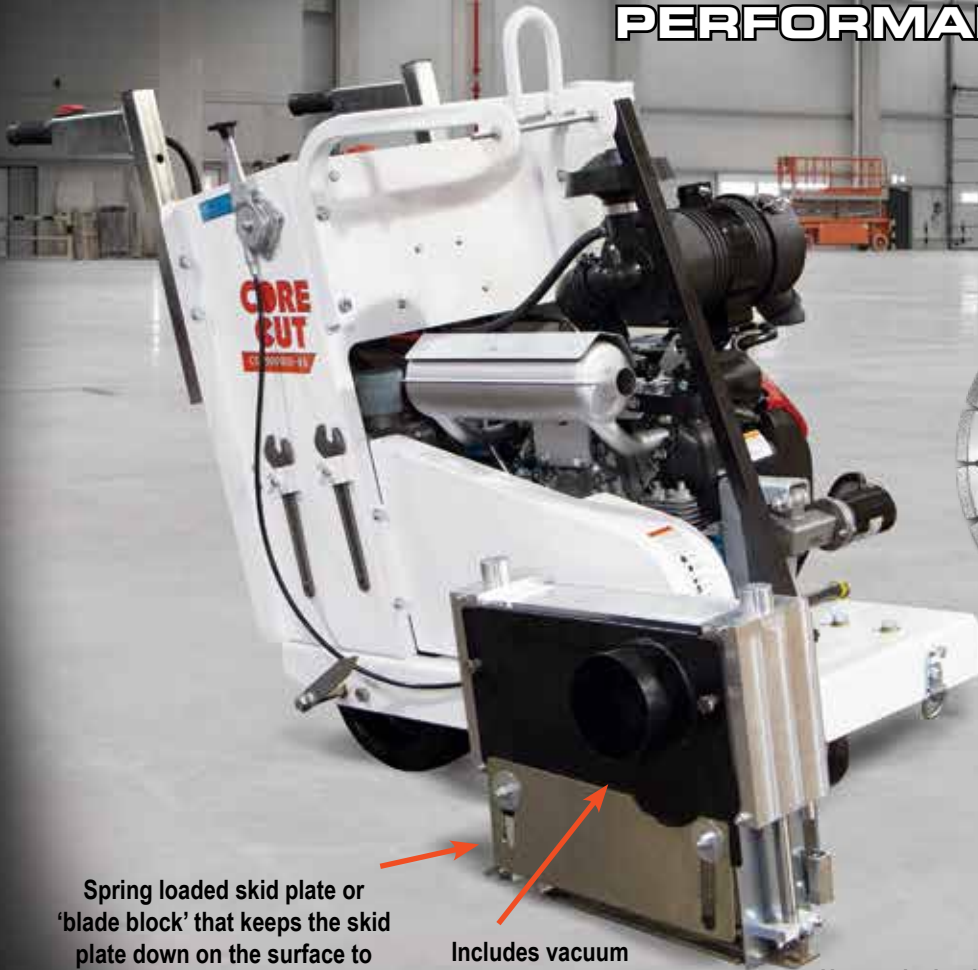

For use with a full line of Basic and Expert diamond blades

Spring loaded skid plate or 'blade block' that keeps the skid plate down on the surface to help prevent spalling

Includes vacuum side cover plate

Up-cut design keeps debris out of the cut line

14" Blade Capacity Gasoline

FEATURES

- Capable of .110" to .250" thick blades
- Self-propelled drive
- Raise and lower adjustable handle bars
- Heavy duty handle design
- Vibration dampeners that prevent rattling that disrupts the skid plate function
- Self aligning blade shaft bearings
- Easy access to battery with heavy duty isolator switch to prevent power drain
- Up-cut design to keep debris from going back in the cut
- Lifting hook for easy transport

Includes: Electric start, low oil alert and tach/hour meter

SPECIFICATIONS

Max. Depth of Cut	1-5/8" with 10" blade 2-5/8" with 12" blade 3-5/8" with 14" blade
Blade Shaft RPM	3500
Blade Shaft Diameter	1-1/4"
Arbor Size	1" with single drive pin
Blade Raise/Lower	Electric actuation
Transmission	Eaton Model 6
Drive Speed	0-80 feet per minute



CC190PRO-EE FIRST-CUT™ SAW

Powered By:



Use the Core Vac CVG1 Vacuum with the CC190PRO-EE saw.
The CVG1 includes hoses.

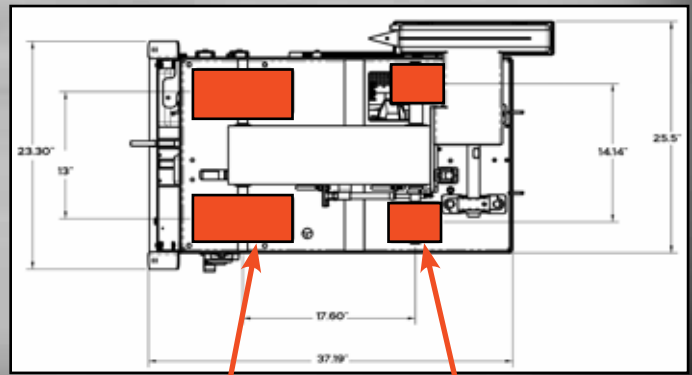
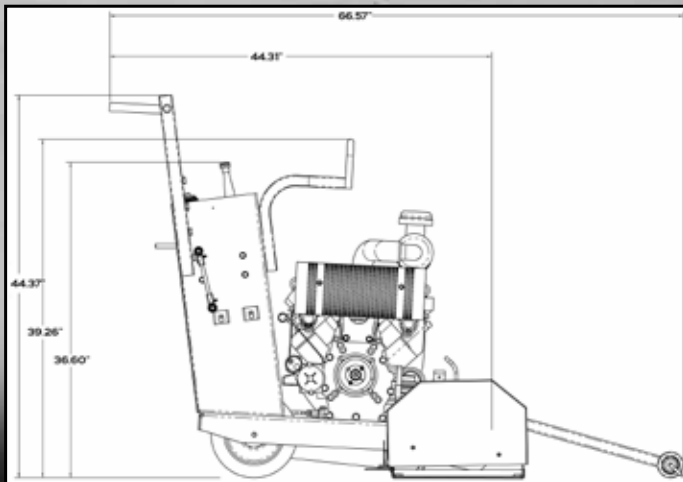

Four wide wheels for saw stability and reliable tracking

CC190PRO-EE EARLY ENTRY SAW

Model #	Engine Make/ Model	Engine Power*	Part #	Cat #	Product Weight (lbs)
CC190PRO-EE	Honda® GX630	20.8 HP, 35.6 Torque (lbs.-ft)	5801128	13364	420

*Horsepower as rated by the engine manufacturer.

CC190PRO-EE OPTIONS

Description	Part #	Cat #
CVG1 Honda dust containment vacuum with hoses - dry only	5801901	102452
CVG1-B Briggs dust containment vacuum with hoses - dry only	5801902	106583
Vacuum side cover plate for CC190PRO-EE blade block	2708358	80580
Vacuum adapter 3" to 5" (manifold assembly 1" - 3" port)	2504846	82102
Spot Light Kit	6047720	78751



BASIC FIRST-CUT™ DIAMOND BLADES

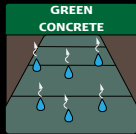

FOR USE ON
FIRST-CUT™ OR
COMPETITOR
SAWS



BASIC - GOOD QUALITY, LONG LIFE Individual Blades - No Skid Plate

SIZE	BASIC1000 Cat #	BASIC2000 Cat #	BASIC3000 Cat #	BASIC4000 Cat #	BASIC5000 Cat #	BASIC6000 Cat #
4" x .080	70113	70114	70116	70117	70119	70120
6" x .100	63013	40544	40546	40547	63014	63016
8" x .100	63056	42938	42939	42943	63058	63063
8" x .125	63365	63371	63372	63373	63380	63381
10" x .110	63382	46593	46596	46599	63384	63388
10" x .250	63389	63390	63392	63396	63397	63404
12" x .125	63413	44970	44971	44974	63415	63416
12" x .250	63417	63419	63420	63421	63422	63423
13.5" x .125	63426	63427	63428	63429	63430	63437
13.5" x .250	63440	63441	63442	63446	63447	63449
14" x .125	63450	44976	44977	44978	63458	63464
14" x .250	63465	63466	63467	63468	63469	63470



L8TR Blade

We know your jobs are unpredictable and things happen. If you missed cutting that green concrete within the two hour Control Zone, don't worry, we've got you covered - even the next day.

Designed for use on our First-Cut™ early-entry saw line or competition saws.

9mm segment design for fast cutting and 14" includes radius drop segment wear protection

First-Cut L8TR Blades

Size	Cat #
6" x .095 x 1"	104440
12" x .125 x 1"	104441
14" x .125 x 1"	104442

SPECIFICATION

L8TR - Fast cutting in green concrete after the Control Zone

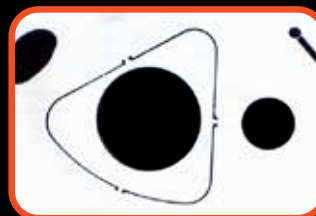

Includes 1" round and triangle knockout for competition-style saws.



BASIC FIRST-CUT™ BLADE PACKAGES



BASIC BLADE PACKAGES Blades With Universal Snap-On Skid Plate

SIZE	BASIC1000 Cat #	BASIC2000 Cat #	BASIC3000 Cat #	BASIC4000 Cat #	BASIC5000 Cat #	BASIC6000 Cat #
6" x .100	64125	64132	64133	64134	64135	64136
8" x .100	64163	64166	64167	64185	64206	64207
8" x .125	64234	64235	64236	64237	64238	64242
10" x .110	64271	64273	64274	64275	64276	64282
10" x .250	64335	64338	64341	64344	64345	64348
12" x .125	64376	64378	64379	64384	64387	64388
12" x .250	64439	64441	64442	64443	64447	64448
13.5" x .125	64471	64473	64474	64479	64482	64485
13.5" x .250	64516	64518	64522	64526	64528	64530
14" x .125	64546	64547	64550	64552	64553	64555
14" x .250	64573	64579	64580	64581	64582	64583

SPECIFICATIONS	
Specifications & Specification Color Code	Aggregate Hardness & Map Color Code
EXPERT1000-Purple	Very Hard
EXPERT2000-Green	Hard
EXPERT3000-Red	Medium Hard
EXPERT4000-Orange	Medium
EXPERT5000-Yellow	Medium Soft
EXPERT6000-Black	Soft

BASIC QUALITY GRADE:

Good cutting life expectation in green concrete.

Consider the **Aggregate Hardness** based on aggregate found in your area and cure time before determining the bond specification. Aggregate hardness can be determined by the aggregate map found at the back of this booklet.

Specification Color Codes follow common industry codes for bond specifications.



First-Cut blades include a 1" arbor with drive pin hole and triangle knock-out. Diamond Products' saws have 1" arbors where some competitor saws have an arbor that accepts the triangle knockout.

EXPERT FIRST-CUT™ DIAMOND BLADES

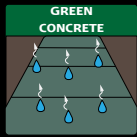

FOR USE ON
FIRST-CUT™ OR
COMPETITOR
SAWS



EXPERT - VERY HIGH QUALITY, LONGER LIFE Individual Blades - No Skid Plate

SIZE	EXPERT1000 Cat #	EXPERT2000 Cat #	EXPERT3000 Cat #	EXPERT4000 Cat #	EXPERT5000 Cat #	EXPERT6000 Cat #
6" x .095	66117	67330	57526	68407	69019	56798
6.5" x 100	90411	---	103521	---	---	---
8" x .100	67332	67331	68352	68328	68380	68331
10" x .110	68782	67318	55816	68498	51150	56801
12" x .080	101118	---	106824	106814	---	---
12" x .125	67326	67325	57524	68512	90673	52597
12" x .250	70590	68507	68590	68515	68475	70118
13.5" x .125	68438	67329	67898	69554	68378	69690
13.5" x .250	69159	70166	69328	69853	68434	68384
14" x .125	68394	68392	57525	68518	51156	51177
14" x .250	68521	70559	68526	68469	68351	69770



- Cleans spalled joints
- Makes decorative finish joints
- Creates a better reservoir for applying joint fillers
- Beveled edges for protecting joints

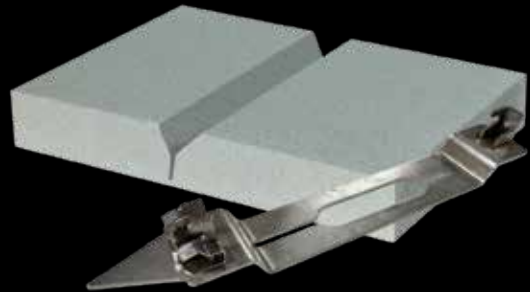
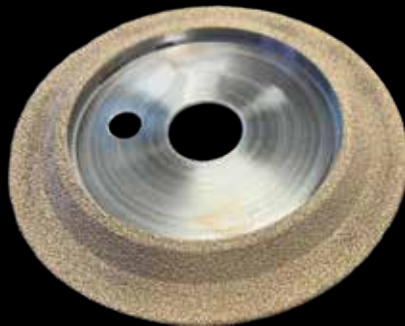

Special Skid Plate for V-Bevel Blades

Universal skid plate that fits Diamond Products and competition saws

First-Cut Bevel V-Blades		
Size/Desc	Part #	Catalog #
6" x .375" (3/8") x 1"	CVBFC06375	106720
6" x .625" (5/8") x 1"	CVBFC06625	106721
Skid Plate Kit*	6052020	106928
Universal Snap-On Skid Plate Only for V-Bevel Blade	2505482	106638

*Includes UNV V-Bevel skid plate, spring block cap, screws and nuts for use on CC150XL to keep the saw at a constant depth for V-Bevel cutting.

Profile View of V-Bevel Blade



EXPERT FIRST-CUT™ BLADE PACKAGES



EXPERT BLADE PACKAGES Blades With Universal Snap-On Skid Plate

SIZE	EXPERT1000 Cat #	EXPERT2000 Cat #	EXPERT3000 Cat #	EXPERT4000 Cat #	EXPERT5000 Cat #	EXPERT6000 Cat #
6" x .095	64145	64147	64149	64150	64155	64156
6.5" x .100	106266	---	107670	---	---	---
8" x .100	64208	64210	64212	64216	64217	64218
10" x .110	64288	64289	64290	64293	64296	64298
10" x .250	106304	106308	106309	107671	107672	107673
12" x .080	106313	---	104049	107669	---	---
12" x .125	64389	64390	64402	64417	64418	64419
12" x .250	64449	64451	64452	64453	64458	64460
13.5" x .125	64488	64489	64493	64494	64495	64498
13.5" x .250	64532	64533	64535	64541	64543	64544
14" x .125	64557	64558	64559	64561	64562	64566
14" x .250	64584	64585	64590	64597	64598	64599

SPECIFICATIONS

Specifications & Specification Color Code	Aggregate Hardness & Map Color Code
EXPERT1000-Purple	Very Hard
EXPERT2000-Green	Hard
EXPERT3000-Red	Medium Hard
EXPERT4000-Orange	Medium
EXPERT5000-Yellow	Medium Soft
EXPERT6000-Black	Soft

EXPERT QUALITY GRADE:

Very long cutting life expectation in green concrete with professional performance.

Consider the **Aggregate Hardness** based on aggregate found in your area and cure time before determining the bond specification. Aggregate hardness can be determined by the aggregate map found at the back of this booklet.

Specification Color Codes follow common industry codes for bond specifications.

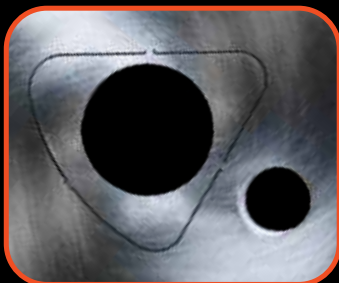

First-Cut blades include a 1" arbor with drive-pin hole and triangle knock-out. Diamond Products' saws have 1" arbors where some competitor saws have an arbor that accepts the triangle knock-out.



Joint Protectors

(50 per bag)

- 2" long x 1/2" wide x 1/8" thick
- Used when making cross-cuts in green concrete
- Prevents joint collapse when cutting across another cut

Part #	Cat #
JOINTPRO-50	17145



SKID PLATES



**UNIVERSAL Snap-On
Skid Plates Fit
Diamond Products Saws
and Competitor Saws.**

Universal Skid Plate Features

- Stainless steel construction
- Snap-on, clip style that fits on Diamond Products First-Cut saws and competition saws
- 1/8" thick bottom plate allows skid to be used for 2-3 blades before requiring replacement depending on the abrasive properties of the aggregate and the diameter of the blade
- Steel mounting pins that won't break or fail like some cast aluminum competitor mounts
- Mounted with a locking pin to keep the plate in place
- Fits both steel and cast skid plate saws

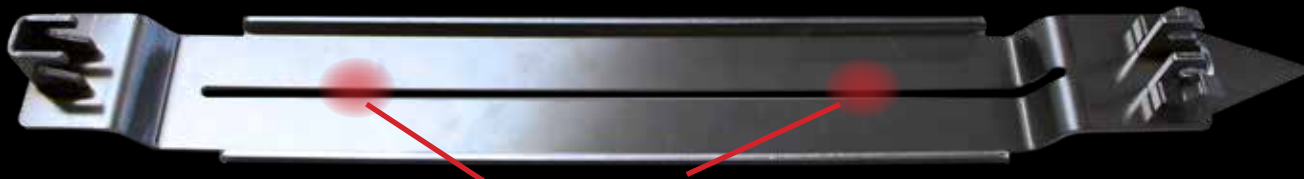

ALWAYS CHECK SKID PLATE BEFORE SAWING!

Look for wear at these highlighted areas on the bottom side of the skid plate. If the slot is no longer a straight line, you must replace the skid plate.

This wear is typically seen every 2 to 3 blade lives depending on the aggregate type.

When Used with Hard Aggregate:

Blades in hard aggregate have shorter life so the skid plate will last longer. This holds true for diamond blades. They wear out faster, which leads to less skid plates being needed due to less abrasion wearing on the steel skid plate.

When Used with Soft Aggregate:

Blades in soft aggregate last longer so the skid plates wear out with fewer blades. Blades specifications for soft aggregate are typically hard, which results in more skids plates being needed due to more abrasion on the steel skid plate.

UNIVERSAL SKID PLATES FOR .125 & .250 THICK BLADES

Description	.125 Part #	.125 Cat #	.250" Part #	.250" Cat #
Skid Plate for 6" and 8" Blades	2505481	105295	2505486	107475
Skid Plate for 10" Blades	2505483	107039	2505487	107476
Skid Plate for 12" and 13.5" Blades	2505484	107040	2505488	107477
Skid Plate for 14" Blades	2505485	107041	2505489	107478

TRUE EARLY ENTRY™ SYSTEM



TRUE EARLY ENTRY™

System Components:

- First-Cut™ blade (2 quality grades-Basic & Expert)
- First-Cut™ saw with skid plate guard system
- Optimal Time of Cutting-Known as the Control Zone™ (2 hours after finishing and before final set)

WHAT ARE TRUE EARLY ENTRY™ CONTROL / RELIEF JOINTS?

As concrete is placed and being finished, chemical reactions begin to take place causing the slab to increase in temperature. Stress, caused by shrinkage, begins to accumulate rapidly. At this time the concrete is looking for relief. If not relieved in a timely manner the concrete will relieve itself, resulting in random cracks appearing across the surface of the slab.

By placing **True Early Entry™** joints at the appropriate spacing (normally 10' to 12' apart) the concrete finds the relief it's looking for and cracks directly beneath the cut.

The timing of **True Early Entry™** joints are critical! Controlling random cracking is all about the timing of the cut, not the depth of the cut. Cuts must be placed between the initial set and the final set of the concrete. This **CONTROL ZONE™** is the optimal cutting time to give concrete relief when it is looking for it the most.

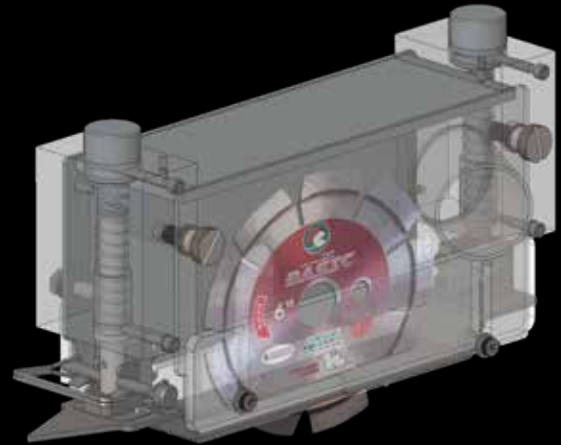

First-Cut™ Skid Plate Guard System

Our First-Cut saws utilize a skid plate guard system that protects concrete spalling during the cut. A spring-loaded skid plate holds it down and keeps aggregate from pulling out of the slab. The guard system is low-maintenance and heavy duty to withstand extended use on the job.



Remember: 2 HOURS after concrete finishing and before the final set.

Why You Need to Use the True Early Entry™ System

Uncontrolled Cracks

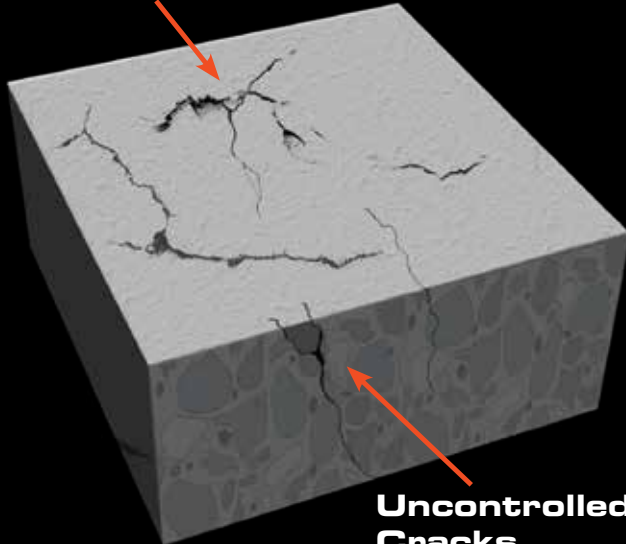

Uncontrolled Cracks

Concrete Without Control/Relief Joint

Without a control or relief joint made into the material, heat and cold aligned with curing can cause expanding and contracting of the concrete, creating uncontrolled cracks throughout. Those cracks will eventually create ruptures and sections that can pull apart from the rest of the material.

Control/Relief Joint

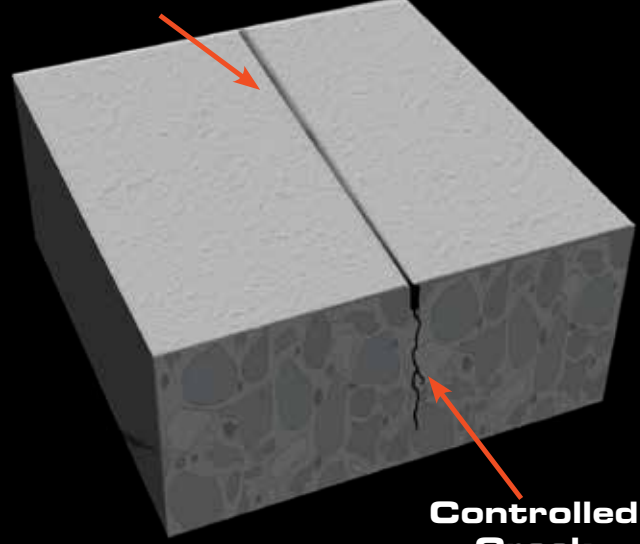

Controlled Crack

Concrete With Control/Relief Joint

Making a controlled cut in the concrete **CONTROLS** where the cracks appear. When this procedure is done in determined spaced sections, the damage and cracking is kept at a minimum which prolongs the life of the concrete slab.



CVG1 VACUUM

CFM - 1,004
Gasoline

HEPA FILTERS



Part of the Core Vac product line for dust removal

FEATURES

- Designed for the contractor who requires a large amount of dust containment.
- NEVER-FAIL patented cleaning system
- Lever style lowering dump system for drum
- Heavy duty casters allow for easy mobility for dumping and transport
- Offers a 5" hose allowing larger air volume and two additional 2" hose inlets for smaller tools
- Less filter cleaning and adaptability to all shrouded equipment

✓ **OSHA COMPLIANT**
with the First-Cut™ System

Vacuum Info

Port Size	CFM
2" - 5"	1004

All testing has been completed in a controlled environment using an air velocity meter and a mechanical gauge measured at the neck of each vacuum. These figures should be used as a reference only.

**For Use on the
CC190PRO-EE
First-Cut Early Entry Saws
and Competition Early
Entry Saws**

CVG1 SPECIFICATIONS

Vacuum Hoses	5" x 15' standard with quick-release clamps
Compressor	2.5 CFM air cooled
Filtration	Special pleated cartridge
Wheels	Two 5" 200lb rubber Two 5" 200lb swivel caster
Height	59" (150cm)
Length	34-1/2" (88cm)
Width	28" (71cm)
Weight	375 lbs. (170kg)

CORE VAC CVG1 DUST CONTAINMENT VACUUM

Description	Part #	Cat #
CVG1 Honda gas vacuum with hoses - dry only	5801901	102452
CVG1-B Briggs gas vacuum with hoses - dry only	5801902	106583
Vacuum side cover plate attachment for CVG1	2708358	80580
Vacuum adapter 3" to 5"	2504846	82102
HEPA Twin Filter	2508947	105768
6 Mil Bag Liner (50 bags) for CVG1	2506170	83300

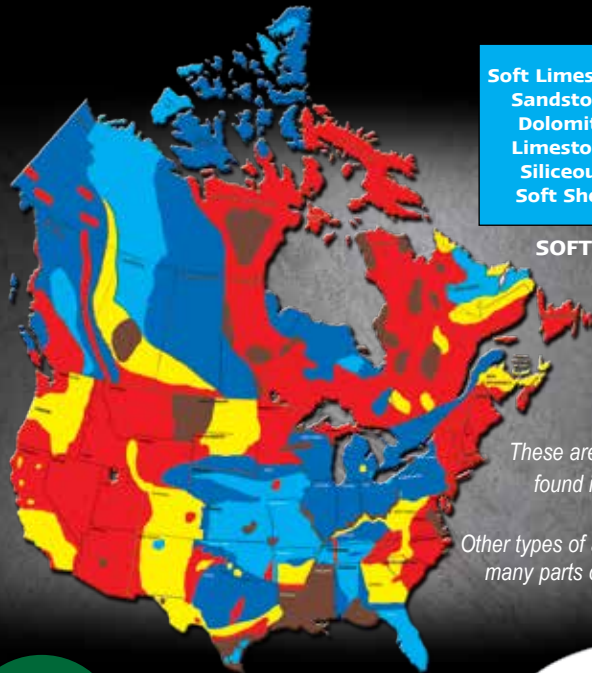

Soft Limestone
Sandstone
Dolomite
Limestone
Siliceous
Soft Shell

SOFT

Pit Gravel
Limestone
Dolomite

MEDIUM SOFT

Med. Hard
River Rock
Med. Traprock
Decomposed
Granite
Med. Crushed
Gravel

MEDIUM

Granite
Slate
Traprock
Basalt
Quartzite

MEDIUM
HARD

Hard Chert
Quartz
Flint Rock
Hard River
Rock

VERY HARD
/HARD

These are the basic aggregates found in the shown areas.

Other types of aggregate can be found in many parts of the U.S. and Canada

BLADE SPECIFICATIONS

FIRST-CUT SPECIFICATION	Aggregate Hardness (see map)
1000/2000	Very Hard/Hard
3000	Medium Hard
4000	Medium
5000	Medium Soft
6000	Soft



DIAMOND PRODUCTS LIMITED
333 Prospect St., Elyria, OH 44035 U.S.A.

800-321-5336
diamondproducts.com