

# Operating Manual

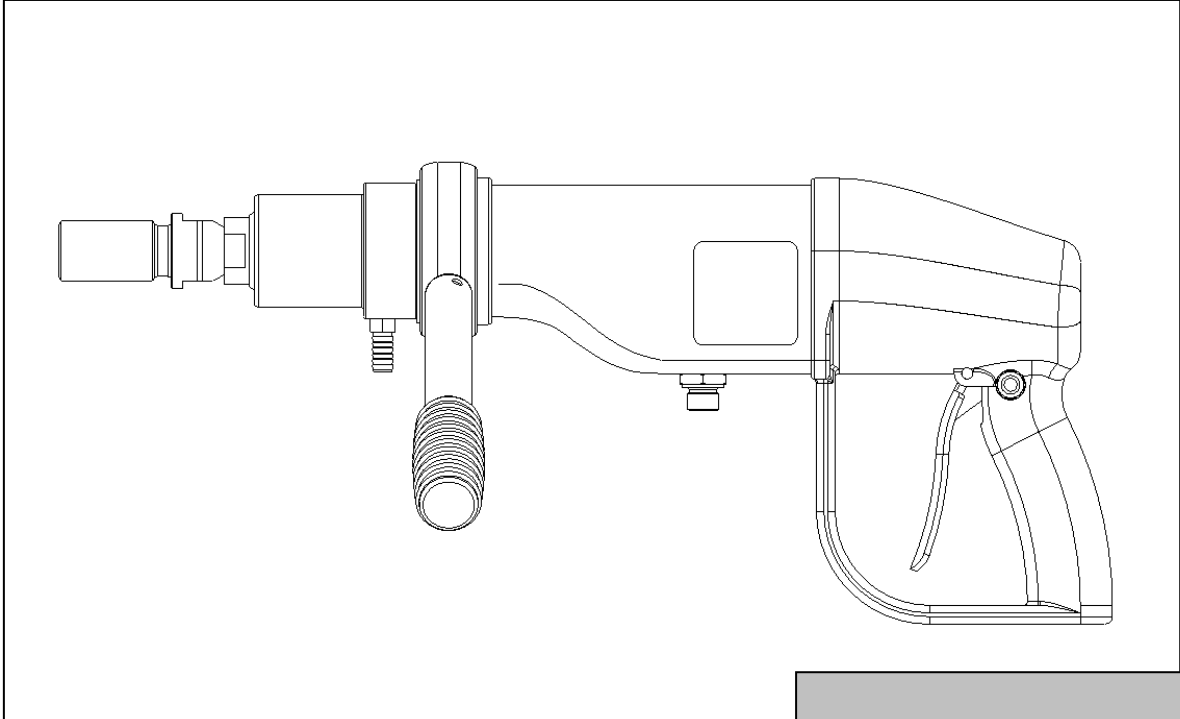

## Hydraulic Core Drill HCD25-100 HCD50-200

From serial No. 0152

Revised 30.08.2011



**HYCON A/S**  
Juelstrupparken 11  
DK-9530 Støvring  
Denmark

Tel: +45 9647 5200  
Fax: +45 9647 5201  
Mail [hycon@hycon.dk](mailto:hycon@hycon.dk)  
[www.hycon.dk](http://www.hycon.dk)

### Prior to Operation

We thank you for choosing a HYCON core drill.

To ensure smooth operation and long-lasting performance of your new core drill, we recommend you to study this operating manual carefully and pay special attention to the chapters about

### Safety and Service Precautions

We hope you will be satisfied with your new HYCON core drill.

Best regards  
HYCON A/S

# Contents

## Page

|                                                          |    |
|----------------------------------------------------------|----|
| Safety Precautions.....                                  | 2  |
| Oil Flow and Pressure .....                              | 4  |
| Useful information regarding the use of core drill ..... | 5  |
| Starting Instructions .....                              | 6  |
| Technical Data .....                                     | 7  |
| Performance Chart .....                                  | 8  |
| Dimensions .....                                         | 9  |
| Connection to Hydraulic Power Sources .....              | 10 |
| Service and Maintenance .....                            | 11 |
| Oil Types .....                                          | 11 |
| EC-Declaration of Conformity .....                       | 12 |
| Warranty Terms .....                                     | 13 |
| Spare Parts List.....                                    | 14 |

## Safety Precautions

- Read the core drill and power source operating manuals prior to use.
- Only use the core drill in accordance with the local working regulations on allowed working time
- Check the oil supply to the core drill. The oil supply may not exceed 20 l.p.m./max. 170 bar. Please refer to page 4.
- Make sure that the core bit is firmly fastened
- For handheld drilling, always use core bits approved for this purpose
- The HYCON core drill is supplied with a trigger lock. This may only be used when drilling in a rig.
- The core drill has an automatic integrated security that makes the core drill stop if the core bit jams. However, in case of jamming, always loosen the core bit from the material, before you start drilling again. The integrated security is set from the factory and may not be disturbed.
- Start the core drill just before you start drilling, and stop it once the drilling is done. Do not let the core drill run freely in the air.
- In case of horizontal drilling or drilling above the head, always be aware of material falling down.
- A fine jet of oil at pressure can penetrate the skin. It is therefore important never to use your fingers to check for oil leaks and never to hold your face close to suspected leaks – use a piece of cardboard instead. If oil has penetrated the skin, you should get medical treatment immediately.
- Never leave the core drill when connected to the powerpack.
- Always use approved hoses. Contact your dealer, if necessary. Mount the hoses correctly so that the core drill rotates in the right direction (clockwise).
- The operator must pay extra attention and show caution when working in difficult working areas, such as slopes and other dangerous nature of the ground. Do not reach too far with the core drill, but always maintain a good footing and keep your balance.
- The operator must be properly trained in using the core drill or under supervision of a qualified instructor.

- The operator must always use protective goggles, earplugs, hard hat and shoes when operating the core drill.
- Never use the core drill close to electric cables. Prior to operation, check whether there are hidden or buried cables.
- Never wear loose clothing as it may get entangled in the moving parts of the core drill.
- Inspection or cleaning of the core drill, change of core bit or disconnection of hoses may never be done while the core drill is connected to the powerpack, as unintentional activation of the core drill can cause severe damage.
- Always connect hoses to the core drill before starting the powerpack. Be sure that all couplings are tight.
- The core drill may not be operated if the oil temperature is above 70 C°. Operation at higher temperatures may result in the core drill getting warmer than normal and the operator risks getting burnt on it.
- To avoid all personal injury and damage to material, all repair, maintenance and service work must be carried out by authorized or properly trained persons only.

## **IMPORTANT**

- A core drill not in use should always be kept in a safe and dry place.
- Always make sure that the core drill labels and warning signs are legible.
- Always use hoses, couplings and spares as such recommend by HYCON A/S.
- Repairs may only be carried out by experienced personnel.
- Make sure that all couplings are cleaned before connection.
- Always disconnect the hydraulic circuit before connecting or disconnecting the core drill. If this is not done, there is a risk of damage to the quick release couplings or the hydraulic system getting overheated.

## **Oil Flow and Pressure**

Your new HYCON core drill is designed for a certain oil flow, working pressure and maximum pressure. A too high oil flow and/or a too high pressure results in overload of the core drill, meaning that the lifetime of your new HYCON tool will not be as expected, and that your service and repair costs will be too high.

It is important to check that the core drill is not supplied with an oil flow beyond its design capacity, that the working pressure is correct and that the maximum allowed pressure is not exceeded.

On page 7 you will find the technical data, and on page 10 there is a guide to connection to hydraulic power sources and how to ensure that the core drill is not overloaded.

# Useful Information Regarding the Use of Core Drill

The HYCON core drill is a small and compact tool with a high performance. There is no other core drill on the market with a higher performance in relation to size.

It is the perfect tool for drilling jobs in all kinds of concrete, brick wall, asphalt etc.

The core drill can be mounted in a rig, but the great advantage of this tool is that all drilling jobs can be done by hand. This is possible due to an automatic security function, which makes the core drill stop immediately if the core bit jams.

The core drill has two handles, and with an 360° infinitely variable adjustment of the front handle, optimum operator comfort is achieved.

The core drill can drill holes from  $\varnothing 50$  mm to  $\varnothing 350$  mm. Drilling jobs beyond  $\varnothing 200$  mm are for experienced users only.

The rotary speed is variable by means of the lever, which facilitates the drilling start.

As handheld drilling is possible for all jobs, the operator saves a lot of time as he does not have to mount a drilling rig prior to operation. For rig drilling, the HYCON core drill can be mounted in the most common drilling rigs ( $\varnothing 60$  mm).

The core drill is unaffected by water and can be operated in all environments – also underwater drilling. This means that there is no shock hazard in excavations etc., as is the case with electric core drills.

The core drill can also be connected to excavators and other machines. We recommend the use of a HYCON oil flow divider to protect the core drill against a too high oil supply, a too high pressure and backwards rotation. Please refer to page 10.

As standard the core drill comes with 1/2" thread and with the adaptor 5/4" thread. This way the core drill can also be used with a 1/2" drill chuck for other drilling jobs, where a percussive function is not applicable.

The core drill is designed for dry as well as wet drilling. The best result is achieved by means of wet drilling, as this cools the core bit and removes the bore meal, thus reducing the wear on the core bit as much as possible.

The utility values of your HYCON core drill are numerous, and we are confident that you will be very pleased with your investment.

# Starting Instructions

## START

- Mount a core bit.
- Connect hoses – clean couplings before connection. Connect water supply.
- Set the power source on "ON".
- Get a good footing, adjust the front handle and lock it. Keep it locked during drilling.
- Press the trigger lever against the handle and start the core drill.
- In case of handheld drilling, start by holding the core bit at an oblique angle towards the material, so that only 1/5 of the core bit diameter cuts the material. When gradually a groove is cut in the material, slowly move the core bit to drilling with the whole diameter. Once a groove is cut on the entire diameter, press the core bit against the material and drill through.
- In case of drilling in a rig, press the core bit slowly against the material, and once a groove has been cut on the entire diameter, increase the pressure on the core bit and keep it stable until the drilling is done.
- A constant and sufficient water supply is important, as it cools the core bit, removes the bore meal and guarantees the best result with as little wear on the core bit as possible.

## STOP

- Remove the core bit from the material and let go of the trigger lever.
- Set the power source on "OFF", and disconnect the water supply.

## Technical Data

|                                                   | <b>HCD25-100</b>                                                  | <b>HCD50-200</b>                                                  |
|---------------------------------------------------|-------------------------------------------------------------------|-------------------------------------------------------------------|
| <b>Weight w/o hoses, core bit and adaptor</b>     | 7.6 kg                                                            | 7.6 kg                                                            |
| <b>Oil supply</b>                                 | 20 l.p.m.                                                         | 20 l.p.m.                                                         |
| <b>Working pressure nominal</b>                   | 100 bar                                                           | 100 bar                                                           |
| <b>Pressure relief valve in power source</b>      | Max. 170 bar                                                      | Max. 170 bar                                                      |
| <b>Max. return pressure</b>                       | 40 bar                                                            | 40 bar                                                            |
| <b>Max. oil temperature</b>                       | 70° C                                                             | 70° C                                                             |
| <b>Rotary speed at 20 l.p.m.</b>                  | 1500 r.p.m.                                                       | 600 r.p.m.                                                        |
| <b>Torque</b>                                     | 20 Nm                                                             | 48 Nm                                                             |
| <b>Sound pressure level 1 m L<sub>PA</sub></b>    | 85 dB                                                             | 84 dB                                                             |
| <b>Vibration level</b>                            | < 2.5 m/s <sup>2</sup>                                            | < 2.5 m/s <sup>2</sup>                                            |
| <b>Core bit size</b>                              | ø25-ø100 mm                                                       | ø50-ø200 mm<br>Up to ø350 mm for the experienced user             |
|                                                   | Thread core bit:<br>External G 1/2" or<br>internal 1 1/4" – 7 UNC | Thread core bit:<br>External G 1/2" or<br>internal 1 1/4" – 7 UNC |
| <b>Necessary cooling capacity on power source</b> | 1 kW                                                              | 1 kW                                                              |



# Performance Chart

**HCD25-100 Core Drill**  
 Performance loss with different lengths of hoses:

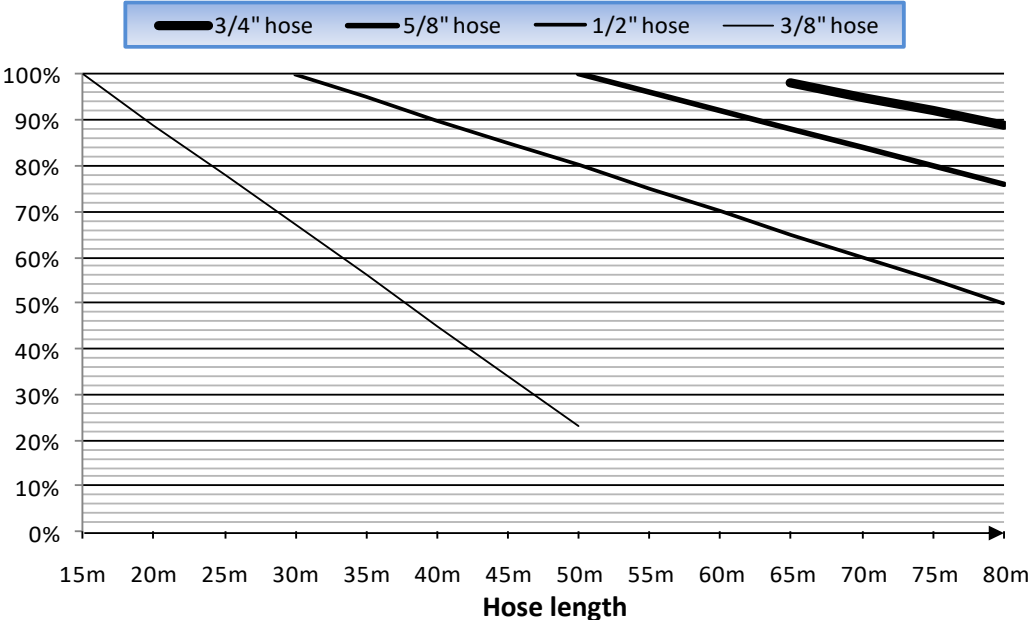

Pressure from power pack: 150 bar., Flow: 20 l.p.m., zero elevation, 2 set couplings per 10 m hose.

**HCD50-200 Core Drill**  
 Performance loss with different lengths of hoses:

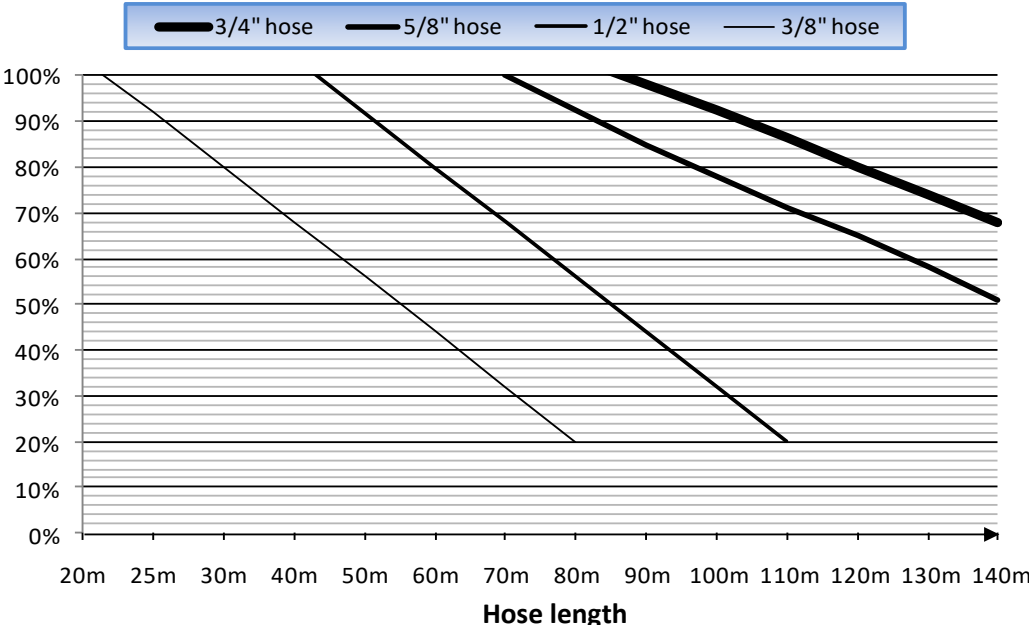

Pressure from power pack: 150 bar., Flow: 20 l.p.m., zero elevation, 2 set couplings per 10 m hose.

# Dimensions

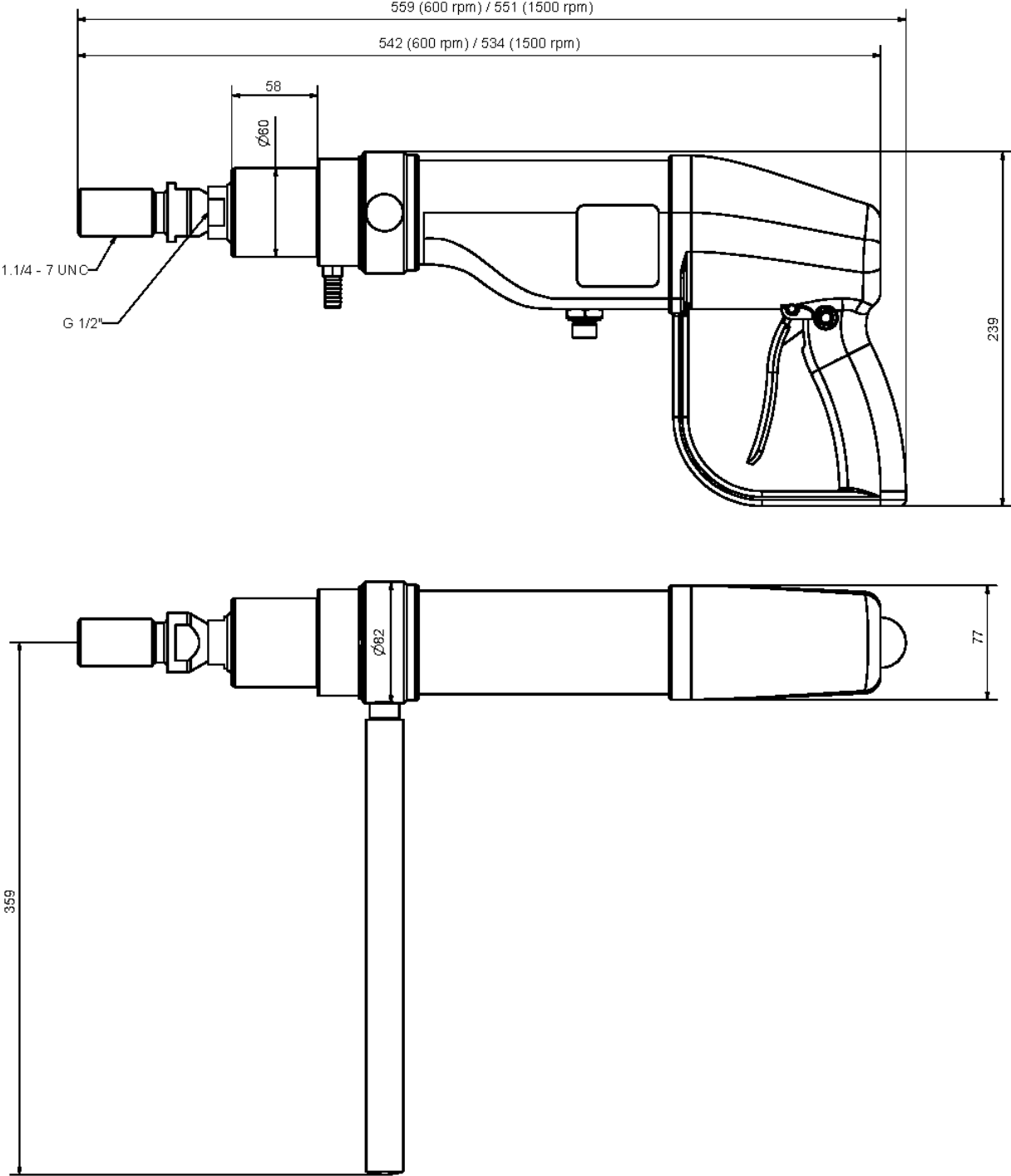

## Connection to Hydraulic Power Sources

The core drill can be connected to various hydraulic power sources, such as excavators, trucks, loaders, tractors etc., and of course HYCON powerpacks, the design of which ensures your new HYCON core drill the absolute best working conditions.

It is important that the core drill is not subjected to an oil flow and a working pressure beyond its design capability. Please refer to the ID-tag on the core drill in case of doubt.

Check the oil flow and the working pressure by means of test equipment. The test equipment should comprise a pressure gauge, a flow meter and a valve for adjustment of pressure.

Make sure that:

- the oil flow is not too high
- the working pressure is not too high
- the return pressure is not too high
- the pressure relief valve is not set higher than 170 bar
- the internal diameter of the hoses is sufficient (min. 3/8")
- all couplings are in order
- the power source is equipped with an oil filter of min. 25 Micron

Hoses with too small internal diameter and/or defect couplings cause the core drill to work with incorrect working pressure.

Your dealer can help you check this.

If the output of the power source is too high:

- the power source must be adjusted to correct output
- or you can choose to mount a HYCON oil flow divider to protect the core drill against overload
- or you can choose one of our HYCON powerpacks. Your dealer can guide you in choosing the right powerpack.

In case of doubt, please contact your dealer or HYCON A/S.

## Service and Maintenance

| Service/Maintenance                 | Daily | Weekly | Yearly |
|-------------------------------------|-------|--------|--------|
| Check couplings and clean carefully | X     |        |        |
| Check hoses                         | X     |        |        |
| Check bearing for clearance         |       | X      |        |

NB. At service/repair it is important to mount the hoses correctly.

### Underwater tools

The HCD is also made in an underwater version and when used underwater we recommend some more cleaning to avoid the tool is aggressive corroded due to the constant water/saltwater contamination.

1. Disconnect the tool from the power pack when finished with the job.
2. Rinse the tool with fresh water immediate after.
  - a. For all tools with a plastic cover, there are holes made for easy cleaning of the internal parts and avoid water is trapped inside.
3. Ensure that all water is out of the tool.
4. Spray all parts with a water dispersal spray – E.g. Liqui Moly – Marine Multi-spray.

### Oil Types

The HYCON core drill uses standard hydraulic oil, i.e. all types of mineral oil and biodegradable oil, which comply with the following values:

|                                        |                    |                            |                    |
|----------------------------------------|--------------------|----------------------------|--------------------|
| <b>Ambient temperature range</b>       | Below 10°C<br>50°F | 10 ... 30°C<br>50 ... 86°F | Above 30°C<br>86°F |
| <b>Recommended oil viscosity grade</b> | VG 32              | VG 46                      | VG 68              |

|                                    |         |                               |
|------------------------------------|---------|-------------------------------|
| <b>Recommended oil cleanliness</b> |         | ISO 4406 /19/16 / NAS 1638 10 |
| <b>Permitted viscosity</b>         | cSt     | 15 – 1000                     |
| <b>Recommended viscosity</b>       | cSt     | 20 – 40                       |
| <b>Viscosity index</b>             | Minimum | 100                           |
| <b>Oil temperature area</b>        | °C /°F  | -20 to 70 / -4 to 158         |

If using biodegradable oil, we recommend the use of oil based on rapeseed. Other types of oil can be aggressive towards the seals. If you are in doubt, please ask your dealer.

# EC-Declaration of Conformity



**HYCON A/S**  
Juelstrupparken 11  
DK-9530 Støvring  
Denmark

Tel: +45 9647 5200  
Fax: +45 9647 5201  
Mail [hycon@hycon.dk](mailto:hycon@hycon.dk)  
**www.hycon.dk**

We hereby declare that

**Core drills HCD25-100 and HCD 50-200 – from serial No. 0152**

is manufactured in conformity with the EC Directives 2006/42/EC

**Notified Body 2914:**

Sweco Danmark A/S  
Ørestads Boulevard 41  
2300 København S  
Danmark

HYCON A/S  
Juelstrupparken 11  
DK-9530 Støvring  
Denmark

A handwritten signature in blue ink, appearing to read "Martin Møller".

Martin Møller  
Managing Director  
22.04.2022



# UKCA -Declaration of Conformity

**HYCON A/S**  
Juelstrupparken 11  
DK-9530 Støvring  
Denmark

Tel: +45 9647 5200  
Fax: +45 9647 5201  
Mail [hycon@hycon.dk](mailto:hycon@hycon.dk)  
**www.hycon.dk**

We hereby declare that:

**Core drills HCD 25-100 and HCD 50-200 from serial No. 0152**

is designed and manufactured in compliance with the UK directives:

|                  |                                               |
|------------------|-----------------------------------------------|
| European Version | UK Version                                    |
| 2006/42/EC       | Supply of Machinery (Safety) Regulations 2008 |

HYCON A/S  
Juelstrupparken 11  
DK-9530 Støvring  
Denmark

Martin Møller  
Managing Director  
02-05-2024

## **Warranty Terms**

We grant 12 months warranty from the first date of operation – however, not more than 18 months from the date of delivery.

The warranty applies to faults that can be related to construction and production errors.

Faults caused by incorrect operation, incorrect handling, lack of maintenance or the like, will not be accepted as warranty.

The warranty covers the parts necessary for repair and the suggested average time needed for repair.

For further warranty details, please contact your local dealer.